

“Join us in discovering
the fire of the future”

 **faber**

EN



Scan me



Discover!

It's what we've always done it's what we do now and what we'll continue to do!

*"It all started 175 years ago.
Developments soon followed.
We became one with the fire.
Controlling the elements, gaining knowledge and continuously innovating.*

*The burning desire to extend our boundaries.
Thanks to the know-how of the past, we look to the future.
We know that the elements can change.*

*Storms, tornadoes and earthquakes have made us wiser.
Low-energy and cosy, that's what matters.
We create sustainable products ready for the future.*

*We make fire from water.
And lighting to determine the atmosphere.
The fuel may change, but one thing stays the same.
We are storytellers and we bring people together.*

*It's what we've always done.
It's what we do now.
And what we'll continue to do in the future."*

Fire by
faber

Why Faber?

Ready for the future!

Finding the ideal fire is often a complex and personal process. Your taste, preference and options offered by your home play an important role. And we are increasingly aware of energy consumption issues and their effect on our habitat. The type of fuel is therefore often one of the first and foremost choices.

When choosing Faber, you are opting for a future-ready fire. You have plenty of choices between 100% electric, or low-energy hybrid gas fires. All with an absolutely amazing fire effect, developed with passion and expertise by our own Fire masters. This makes Faber a market leader in the transition to sustainable, top-quality ambient fires.

Choose from a range of designs, decorations, options, or even opt for energy-saving atmospheric lighting. For a fire to suit you, offering many years of carefree enjoyment.

For more information, please refer to our website; faberfires.com. Or why not visit one of our selected sales partners? And convince yourself of the fire of the future!

**Faber means a choice for
100% electric fires
based on water vapour technology..**



e-Matrix

...or for modern and low-energy gas fires combined with the latest lighting technology.



Suitable for (bio)propane.

Each Faber gas fire can be supplied for use with (bio)propane. Each Faber fire can also be converted to (bio)propane at a later date, up to 10 years after purchase from the official Faber dealer. What a comforting thought, in case a natural gas network is (no longer) available.

Hydrogen – the future

Some countries have already started mixing hydrogen and natural gas. That will become increasingly common in the future. Research has already proven all current Faber gas fires to be suitable for such a hydrogen mix. In other words: Faber is ready for the future.



Quality and safety

All our products comply with the latest CE EN standards for gas and electric fires. In doing so, we comply not only with external testing bodies (such as KIWA.com) but also our extensive internal quality management system.

Service

And in the unlikely event of a problem, you can of course rely on us. We offer extensive service on all our products within the factory warranty period of two years. Service requests can often be provided in situ via a network of selected service partners and our own service department.

Stay informed of our latest product developments?
Follow our socials

@faberhaarden



FaberInternational



e-MatriX:
**Amazing fire...
created from
water**



Scan me

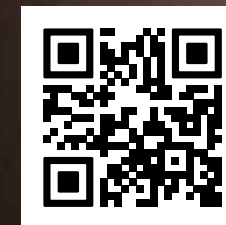

Discover!



Why opt for the e-MatriX?

- No flue-gas pipe required; easy installation anywhere,
- Unique patented three-dimensional “living” fire effect; 100% fire experience,
- Adjustable heat; up to max. 2 kW,
- Simple operation via remote control or the Faber app (supplied standard) for even more options,
- Choice of decoration; log set, white Carrara pebbles or Acrylic ice
- With optional extras including top and/or bottom lighting for an even more realistic fire experience,
- Available in various sizes and as a front, 2 and 3-sided version, Room divider or See-through model,
- Low-energy, 0% emissions, 100% fire effect!

In other words: The fireplace for any season.



Pure enjoyment:

A playful, three-dimensional fire effect

Model:
e-MatriX - MOOD
800-500 II

Modern houses generally need very little additional heat. A log fire is often not an option or is undesirable. Building without gas is a current topic. We increasingly live in urban areas, where flue gases cannot always be discharged. The unique properties of the Faber e-MatriX make it possible to enrich your home with a splendid fire! The fire experience is down to a combination of rising cold water vapour and special LED lights. You can even hear the crackling sound of a fire. Always different, fascinating and convincing... Just what you expect from a real log fire, but without the traditional limitations!

Inspirational and 'future-proof'

You don't need a gas connection, a flue-gas pipe or heat-resistant insulation. Emissions are nil too. Building regulations for using a gas or log fire do not apply, making it much easier to build in than gas or log fires and creating room for ground-breaking design. These fires can be incorporated pretty much anywhere at all!

What about the energy consumption? Minimal!

Without the optional heat function, the energy consumption of the e-MatriX is comparable to ordinary room lighting. The (tap) water consumption remains limited to just a few litres per 24 hours when in use.



The burner - fascinating and sustainable

The astonishing flame effect of the e-MatriX is down to a combination of rising cold water mist and low-energy (LED) lights, with no odour or smoke and therefore 100% sustainable. The result is sheer enjoyment: a playful, three-dimensional fire effect that moves up from the softly glowing embers between the logs to the top of the fire. The flame height is fully adjustable. You can even hear the sound of a crackling fire. An ultra-thin flexible water hose and a regular socket are all that's needed for the connection. A unique way of enjoying a 'log' fire, developed and patented by Faber.



Mood lighting - extra ambience, at any moment

Our optional Mood lighting lifts the flames effect of the e-MatriX to a level previously unknown. The newly developed LED light optics of this option provide dynamic lighting, both under the entire ember bed and throughout the interior of the fireplace. The light intensity, movement and even colours can all be adjusted to suit your mood. This option gives a strikingly warmer and even more natural look to the flames and glowing effect, while also enhancing your view of the interior, even without 'flames'. All the options can be quite simply adjusted via your Faber app, to suit your atmosphere, mood or style. Or simply choose one of the preprogrammed settings. This option truly enhances the look of your fireplace, and really should be a part of your experience. Available for all e-MatriX Fires.



Wonderful heat in front of the fire

Are you sitting near the fire and you'd like to feel the radiating warmth? No problem! The e-MatriX is fitted with a compact and virtually silent (extra) heating unit. The heating unit is incorporated invisibly in the fire. When you want, a warm air flow comes your way through the glass. A sensation that makes the experience even more complete. This additional heating unit has a capacity of maximum 2 kW and a thermostat function. The fire can be simply controlled using the enclosed remote control or by installing the Faber App. Giving you optimum control of the heat from your fire at all times.

New!

This season, Faber will introduce a new, exclusive top model of the e-MatriX series: the Vertical. The first electric vertical fireplace ever!

Vertical fireplaces are growing in popularity in Europe and are real eye-catchers in homes, penthouses, exclusive restaurants or hotel lobbies. The so-called “see-through” variants in particular are very popular because they make it possible to connect multiple spaces in a visually appealing way.

With our new e-MatriX Vertical we are responding to this clear market demand and because it is 100% electric, we also offer a unique proposition. Thanks to our patented water vapor technology, we are the only fireplace manufacturer in the market to offer a fully-fledged vertical see-through fireplace. Add to this the lack of an exhaust need and the application possibilities are endless!

More information?

Contact your local Faber specialist or visit our website.



Scan me



Discover!



Why opt for the e-Matrix Vertical?

- Unique, the only 100% electric, vertical see-through fire on the market.
- At a height of 160 cm and 80 cm wide; one of the largest available vertical fires,
- Adjustable RGB LED lighting; for an even more realistic flame effect,
- Choice of decoration; log set, white Carrara pebbles or Acrylic ice,
- Optional base lighting for an even better mood effect,
- Adjustable heat; 1 or 2 kW,
- Simple maintenance via the stylishly integrated door,
- Operated via the enclosed remote control or the Faber App for even more options,
- Low-energy, 0% emissions, 100% flames!

In other words: Unique vertical electric fireplace with unprecedented possibilities for high-quality interior design.

A Faber e-Matrix fire

What are my choices?



 e-Matrix Mood fires
800/500

 e-Matrix Mood fires
800/650

 e-Matrix
Linear fires
1050/400

 e-Matrix
Linear fires
1300/400

 e-Matrix
Vertical fires
800/1600

Available in the models:

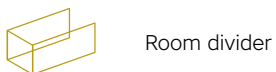
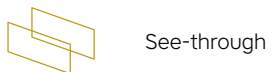

Available in the models:



Available in the models:



Available in the models:



Available in the models:

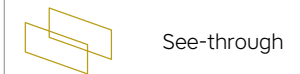

Choose from the various options (at a surcharge)

The e-MatriX models offer various options for fires. In the Mood and Linear fires, you are free to choose your favourite decoration. Options are a log set, white Carrara pebbles or Acrylic ice.



Lighting

Our optional lighting lifts the flames effect of the e-MatriX to a level previously unknown. The newly developed LED light optics of this option provide dynamic lighting, both under the entire ember bed and throughout the interior of the fireplace. The light intensity, movement and even colours can all be adjusted to suit your mood. Would you simply like extra light at the base? That's not an issue, as both light modules can be separately ordered.

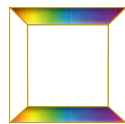
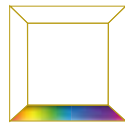
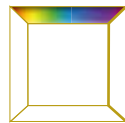

More benefits:

Including:

- Additional electric heating unit
- Choice of decoration
- Faber App controls
- Inset depth 50 mm

Options:

- Non-reflective glass
- Black glass rear wall
- Wall bracket (if applicable)

More information?

Do you want more information about our models, technical data of our fireplaces and line drawings? Ask the local Faber specialist or visit faberfires.com.





Matrix Hybrid: The unique 'play' between gas and light



Scan me



Discover!

Why opt for the Matrix Hybrid?

- Up to 50% less gas consumption; without sacrificing the natural flame effect,
- The (optional) Hybrid Pro Light module gives even richer flames; even at the lowest setting,
- Horizontal flame effect with equally distributed flames over the entire width of the fire,
- No less than 7 individual burners offer unequalled adjustment possibilities; always the perfect flames for any situation,
- Adjustable heat output from maximum 10 down to a mere 1.5 kW; therefore also ideal for modern, well insulated houses with relatively limited heat requirements,
- Available in various sizes and as a front, 2 and 3-sided version, Room divider or See-through model.

In other words: A modern and extremely low energy gas fire offering endless possibilities.



Rich flames

half the natural gas

Our hybrid MatriX ambient fires are electrically supported using LED lighting; comparable with hybrid cars. This low-energy light source has been applied to partially replace the gas flames and to enrich the glowing fire. This unique ‘play’ between gas and light, known as ‘Hybrid Pro Lighting’ (HPL) gives rich flames whose intensity and experience beats any standard gas-fired fireplace. What’s more, this HPL module can reduce gas consumption, CO2 emissions and heat transfer by more than 50%.

Same convenience, more intense flames

The recent introduction of the MatriX Hybrid gas fireplace has triggered a revolution. Thanks to their convenience, safety, clean technology and appearance, this gas fireplace has after all become an attractive alternative for a wood fire, for example.

Faber has once again stepped beyond the limits of the fireplace world. If you’re thinking: less ‘real’ flames means ‘a less realistic fire’, think again. The ‘HPL’ LED technology actually adds a new dimension to gas fireplaces, allowing you to create even more impressive flames with the same convenience but less gas. All by simply pressing the remote control, or clicking your smartphone or tablet.



The burner - The innovative Log Burner® 3.0

The new Log Burner® 3.0 is the latest Faber development, and is truly innovative in efficient, hybrid burner technology. The Log Burner® 3.0 is a newly developed version of our successful Log Burner® 2.0. The burner tubes are no longer straight and round, but rather follow the natural contours of the wood logs. This gives the log set an amazingly realistic look, and the flames flicker in precisely the right place. The fire switching process is phased, distributing the flames accurately among the 7 burners, to give multiple fascinating flame patterns. What's more, this burner is suitable for the LED technology of the (optional) HPL module. This combination results in a uniquely full and lavish fire and ember bed, while reducing gas consumption and heat production by up to 50%! The main functions can be simply operated using the remote control supplied, while the Faber app offers extra operating functions.



Hybrid Pro Light Module

The Hybrid Pro Light module is our breakthrough in terms of glowing effects. With the HPL module, in addition to the glow bed, the logs are also provided with a natural glow for an even more intensive fire image. The Hybrid Pro Light module is a further development of our successful Symbio® glow bed lighting module. Thanks to this ingenious system of LED light projection, Faber's Vuurmakers have succeeded in creating an unprecedentedly fascinating overall image of flames, twinkling logs and coals at a very low heat setting. As if you are looking directly into a fully burning fire, but with half the gas consumption and the corresponding heat production!



Perfect cosiness, even at the lowest setting.

Reducing gas consumption boosts sustainability and more and more houses are effectively insulated and equipped with efficient heating systems. That affects the function of gas fireplaces. They are no longer simply essential for heating purposes, but all the more for creating a cosy atmosphere! And that's a good thing, because the Faber hybrid gas fireplaces were designed specially to give rich flames with the least possible gas consumption and limited heat production. In fact: thanks to the HPL module, these fireplaces give perfect cosiness even without the use of the gas flames!

MatriX Linear:

The ultimate panoramic gas fire



Scan me

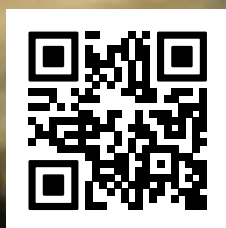

Discover!

Our Linear Fire models offer a lavish fire effect over almost the full width of the fire and that is true for every flame height. Even with a minimum heat output, the flames of this model look fabulous. There is a choice of three inset widths, each of them in three versions and with various interior decorations.

The burner - Faber Double Line Burner

The fire of the Double Line Burner burns with regular and particularly full flames across the entire width of the fire. You can have the fire burn just at the front (single row) or at the back too (double row), for a full fire effect and extra heat. The fire starts up in just a few seconds and the height of the flames can be set with accuracy.

Lavish flames with plenty of choices

There is a choice of three inset widths, each in three versions and with various interior decorations. The Linear Fires combine a popular width and height with a good view of the flames. These versions add considerable extra length, to emphasise the low silhouette of the linear reach, while still enjoying beautiful flames over the entire length of these impressive fires. For decoration there is a choice of beautiful, horizontal logs on an ember bed, or a bed of stylish white Carrara pebbles. The main functions can be simply operated via the remote control supplied, or why not install the Faber App to operate your fire via your smartphone or tablet?



Why opt for the MatriX Linear?

- Extra wide and low gas fire; up to 130 cm of flames!
- Double row of individually adjustable burners; for more intensive flames and added heat output,
- Choice of luxury ceramic log set or white Carrara pebbles for an extra modern and luxurious look;
- Adjustable heat output; from maximum 10 to minimum 4 KW.
- Available in various sizes and as front, 2 and 3-sided models.

In other words: an impressively sized fire with fantastic flames.

MatriX: The all-rounder in a traditional camp-fire design

The MatriX models are recognisable by their camp-fire design of logs. The fire effect of our MatriX fires is incredibly realistic at any flame height. Thanks to the various dimensions, models and options, the MatriX will meet extremely wide-ranging cosiness requirements.

The burner - Faber Log Burner® 2.0

The Log Burner® 2.0 brings memories of a flickering camp fire to life in a fabulous way; with standing logs in the middle, surrounded by lying blocks. You can choose to have the fire burn just in the middle, or all around too. The fire starts up in just a few seconds and the height of the flames can be set with accuracy. The ember bed is lit from below by the ember bed lighting. It makes the fire look full and rich, with a warm glow, even when the flames are set low. The glow can also be switched on separately, like the last glowing embers of a fire. The main functions can be simply operated via the remote control supplied, or why not install the Faber App to operate your fire via your smartphone or tablet?

Symbio® ember bed lighting

Symbio® sends gently pulsating, heat-free light to the ember bed above, making it glow a warm red. The light of the Symbio® module creates a warm atmosphere, particularly when the flames of the fire are turned down low, and even when the warm flames are completely switched off. The LED lighting makes this module low in energy and completely free of heat.

Scan me

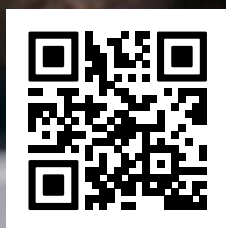

Discover!



Why opt for the MatriX:

- Plenty of choice in sizes and models; there is always a MatriX fire to suit your situation.
- With (optional) Symbio® ember bed lighting; for an even richer fire effect with an ember bed, even without the use of the flames,
- High flames with realistic ceramic logs in a traditional camp-fire design.
- 5 adjustable burners; with 2 settings for an extra deep and intense effect,
- Adjustable heat output; from maximum 10 to minimum 4 kW.
- Available in various sizes and as a front, 2 and 3-sided version, Room divider or See-through model.

In other words: a modern gas fire in a classic “camp-fire” design to offer a solution for every imaginable situation.

A Faber MatriX fire

What are my choices?



 MatriX fires
450/500

Available in the models:



 MatriX fires
450/650

Available in the models:

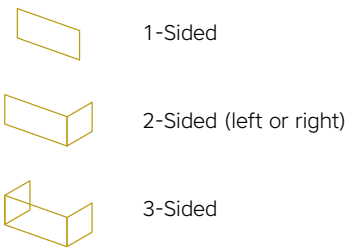

MatriX Log Burner® 2.0



 MatriX fires
800/500

Available in the models:

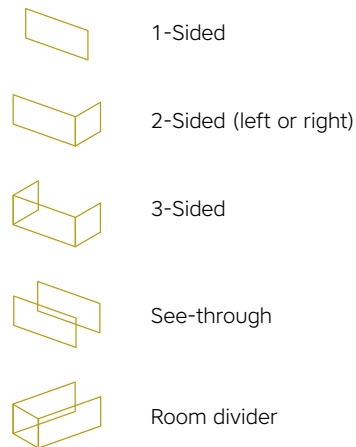

A choice of:

MatriX Log Burner® 3.0
MatriX Log Burner® 2.0



 MatriX fires
800/650

Available in the models:

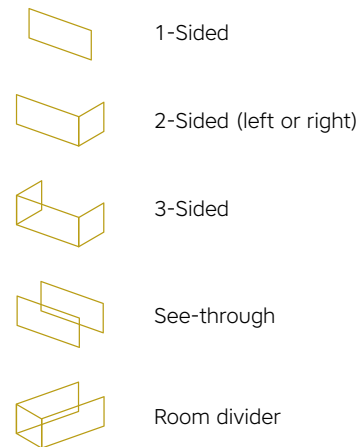

A choice of:

MatriX Log Burner® 3.0
MatriX Log Burner® 2.0



 MatriX fires
1050/500

Available in the models:

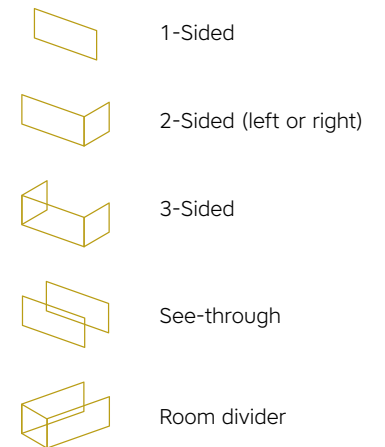

A choice of:

MatriX Log Burner® 3.0
MatriX Log Burner® 2.0

More information?

Do you want more information about our models, technical data of our fireplaces and line drawings? Ask the local Faber specialist or visit faberfires.com.



Matrix fires
1050/650

Available in the models:



1-Sided



2-Sided (left or right)



3-Sided



See-through



Room divider

A choice of:

Matrix Log Burner® 3.0
Matrix Log Burner® 2.0



Matrix Linear Fires
800/400

Available in the models:



1-Sided



2-Sided (left or right)



3-Sided

Double Line Burner
Take note: end-of-range model, limited availability

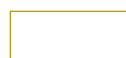

Matrix Linear Fires
1050/400

Available in the models:



1-Sided



2-Sided (left or right)



3-Sided

Double Line Burner



Matrix Linear Fires
1300/400

Available in the models:



1-Sided



2-Sided (left or right)



3-Sided

Double Line Burner

Choose from the various options

(at a surcharge)

Including:

Faber app controls*
Inset depth 50 mm
Choice of decoration**

Options:

Inset depth 30 mm
Inset depth 100 mm
HPL Module (Log Burner® 3.0)
Symbio® Module (Log Burner® 2.0)
Non-reflective glass
Black glass rear wall
Adjustable feet
Wall bracket (if applicable)

Choose your own style of decoration for a Linear Fire. The options are a modern log set or white pebbles.



* with the exception of the 450 models)

** only for the Linear models

The Faber app

Convenience equals enjoyment



Operate your fire very simply using the app

All Faber (e-)MatriX fires can be operated not only using the remote control supplied but also via our own Faber App.

Thanks to the Faber App, you can control the functions and settings of your fire. Optimum control from the screen of your own tablet or telephone.

The Faber App gives access to a wide range of settings, alongside the standard functions. You can also opt for 1 of the 5 special mood pre-settings for MatriX gasifiers: constant, relaxed, camp-fire, party & eco. In the electric e-MatriX models, all the various lighting and colouring options can be entirely adjusted to your own requirements via the App.

The Faber App allows you to control all the options and settings. It also provides the specialist with clear insight into the technical heart of the (e-)MatriX fire in case of a malfunction. Moreover, the app ensures that users are reminded of the need for periodic servicing, even including the contact details of the specialist/ dealer.



Check out our full range for inspiration
and possibilities at:
www.fabers.com

